

DETAIL A
SCALE 1.2 : 1

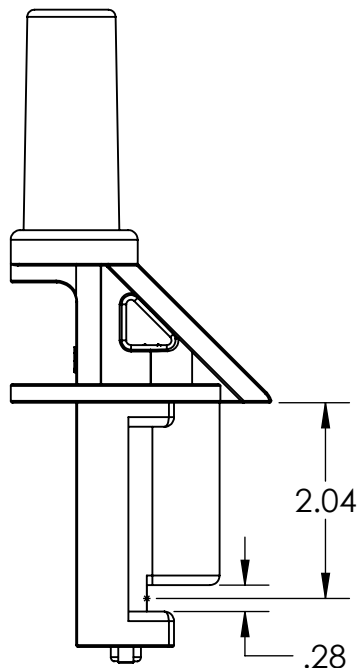

NOTE: Distance to inside of Pipe from this point is 0.8".

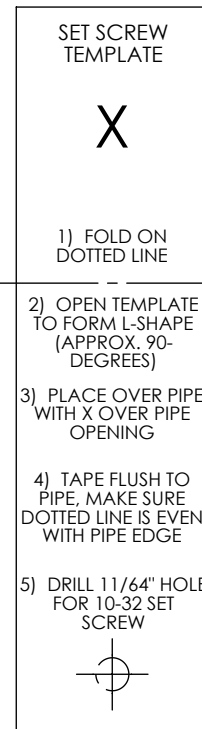

Cutout template on solid line

-18-8 SS flat point socket set screw 10-32 thread, 1" length.

-Tighten set screw until just flush with pipe (assumes schedule 40 pipe).

TITLE: WiSI_Setscrew

RUGID COMPUTER, INC.

P.O. Box 14520
Tumwater, WA 98511, USA
P: 360.866.4492
E: info@rugidcomputer.com

www.rugidcomputer.com

